

FEATURES

- Possibility of controlling up to 16 DALI ballasts and up to 16 lighting groups
- Possibility of controlling up to 2 DALI inputs
- Multi-Master DALI-2 Controller
- Compatibility with emergency lighting (DT1), color ballasts (DT8) and energy monitoring (DT51)
- Supports KNX Data Secure
- Configuration and commissioning through ETS App
- Scene sending and saving. HCL function
- Error detection and monitoring
- Burn-in, Stand-by and Auto-off functions
- Manual control through button
- Total data saving on KNX bus failure
- Integrated KNX BCU (TP1-256)
- Dimensions Ø 51.7 x 26.6 mm
- Can be mounted within distribution boxes or wall back boxes
- DALI-2 Standard certified
- Conformity with the CE, RCM directives (marks on the back side)

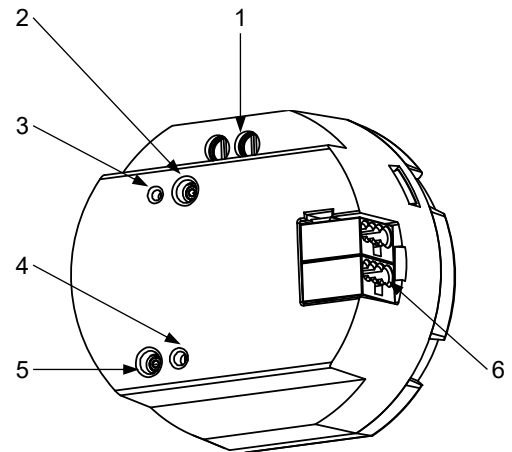

Figure 1: inBOX DALI 16

1. DALI bus channel	2. Output control button	3. Output status LED
4. Programming/Test LED	5. Programming/Test button	6. KNX connector

Programming/Test button: short press to set programming mode. If this button is held while plugging the device into the KNX bus, it enters the safe mode. If this button is held for more than 3 seconds, the device enters the test mode. In order to perform a KNX Secure factory reset, while the device is in safe mode, press the button for 10 seconds until the programming LED changes its state.

Programming/Test LED: programming mode indicator (red). When the device enters the safe mode, it blinks (red) every half second. The test mode is indicated by the green color. During the start-up (reset or after KNX bus failure) and if the device is not in safe mode, it emits a red flash. The identification in a DALI commissioning is indicated in blue color.

GENERAL SPECIFICATIONS

CONCEPT		DESCRIPTION	
Type of device		Electric operation control device	
KNX supply	Voltage (typical)	29 VDC SELV	
	Voltage range	21-31 VDC	
	Connection type	Typical TP1 bus connector for 0.8 mm Ø rigid cable	
	Maximum consumption	Voltage	mA
29 VDC (typical)		39.8	1154.2
24 VDC ¹		50	1200
External power supply	Voltage	Not required	
	Maximum consumption	0	
Operation temperature		0 .. +55 °C	
Storage temperature		-20 .. +55 °C	
Operation humidity		5 .. 95%	
Storage humidity		5 .. 95%	
Complementary characteristics		Class B	
Protection class / Overvoltage category		II / III (800 V)	
Operation type		Continuous operation	
Device action type		Type 1	
Electrical stress period		Long	
Degree of protection		IP20, clean environment	
Installation		Independent device to be mounted inside distribution boxes or wall back boxes	
Minimum clearances		Not required	
Response on KNX bus failure		Data saving according to parameterization	
Response on KNX bus restart		Data recovery according to parameterization	
Operation indicator		The programming LED indicates programming mode (red). The output LED indicates its status (fixed = active output; flashing = error in the output)	
Weight		60 g	
PCB CTI index		175 V	
Housing material		PC FR V0 halogen free	

¹ Maximum consumption in the worst-case scenario (KNX Fan-In model).

DALI OUTPUT SPECIFICATIONS AND CONNECTIONS	
CONCEPT	DESCRIPTION
Number of channels	1
Output type / Voltage	DALI bus / 18 VDC FELV
Guaranteed current per channel	32 mA
Maximum current per channel	250 mA
Maximum DALI ballasts per channel	16
Maximum length of cable	300 m (@ 1.5 mm ²)
Short-circuit protection	YES
Overload protection	YES
Over-voltage protection	YES
Connection method	Screw terminal block (0.4 Nm max.)
Cable cross-section	0.5-2.5 mm ² (IEC) / 26-12 AWG (UL)

WIRING DIAGRAMS

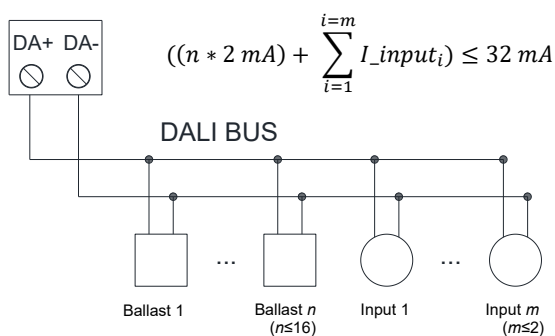

DIMENSIONS (mm)

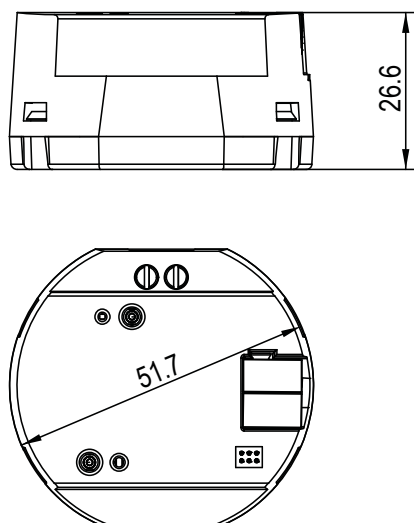

- ⚠ In case of ballast replacement, please follow the steps defined in the user manual.
- ⚠ In case of a DALI channel short circuit, the device will monitor the DALI channel in order to switch on the output at full current just as the short circuit is removed.
- ⚠ The total current consumed by the ballasts and inputs devices must not exceed the guaranteed current per channel.
- ⚠ It is recommended to not exceed a maximal current of 16 mA in input devices in order to maintain part of the available device's capacity for use of control gears.

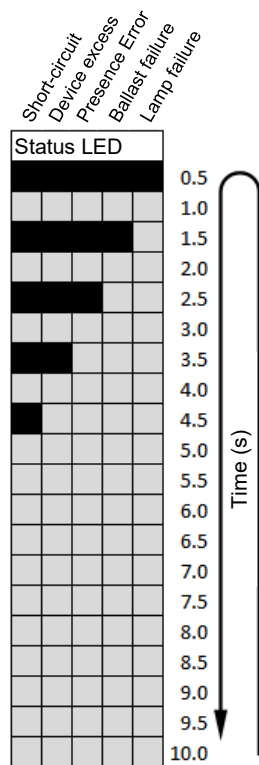

Figure 2. Error notifications

SAFETY INSTRUCTIONS AND ADDITIONAL NOTES

- Installation should only be performed by qualified professionals according to the laws and regulations applicable in each country.
- Do not connect the mains voltage nor any other external voltage to any point of the KNX bus; it would represent a risk for the entire KNX system. The facility must have enough insulation between the mains (or auxiliary) voltage and the KNX bus or the wires of other accessories, in case of being installed.
- Once the device is installed (in the panel or box), it must not be accessible from outside.
- Keep the device away from water (condensation over the device included) and do not cover it with clothes, paper or any other material while in use.
- The WEEE logo means that this device contains electronic parts and it must be properly disposed of by following the instructions at <https://www.zennio.com/en/legal/weee-regulation>.
- This device contains software subject to specific licences. For details, please refer to <https://zennio.com/licenses>.